

**PRAETOR**<sup>®</sup> 500E  
BY EMBRAER



EMPOWERING GLOBAL AEROSPACE THROUGH EFFICIENCY & INNOVATION

Embraer is creating tomorrow's world of air travel today, utilizing industry-leading innovation, design, and technology—all the while incorporating sustainable and socially responsible practices.

As a global company with more than 55 years in aviation, Embraer is empowering aerospace through engineering excellence, enterprise efficiency and a customer-centric philosophy.

Every day, Embraer business aircraft operate around the globe, supported by a strong, responsive customer support network that's top-ranked across the industry. For more information, visit [embraer.com/executive](https://embraer.com/executive).

# MAXIMIZE YOUR EXPERIENCE





See it in action.





**PRAETOR<sup>®</sup> 500E**  
BY EMBRAER



Learn more



Best-in-class performance. Industry-leading technology. Unrivalled comfort.  
Own the sky onboard the fastest and furthest-flying midsize jet.





# HIGHLIGHTS

**Next-Gen Cabin Management System (CMS):**  
Intuitive control of lighting, entertainment and environment.



**Full fly-by-wire:**  
The first and only midsize jet with full fly-by-wire with active turbulence reduction.

**Advanced seat engineering:**  
Maximized ergonomics, increased legroom and improved berthing process.



# HIGHLIGHTS

**Best-in-class range:**  
Extend your reach with  
a continental range of 3,340 nm.



**Best-in-class speed:**  
Speeds up to Mach 0.83



**Lowest cabin  
altitude in class:**  
5,800 feet while  
cruising at 45,000 feet.

INDUSTRY-LEADING  
TECHNOLOGY



UNRIVALED  
COMFORT



BEST-IN-CLASS  
PERFORMANCE



Today's leaders must go above and beyond what's expected. Their aircraft is no different. The Praetor 500E delivers disruptive technology, best-in-class performance capabilities and unprecedented comfort for transcontinental travel.

**PRAETOR<sup>®</sup> 500E**  
BY EMBRAER

INDUSTRY-LEADING  
TECHNOLOGY



# A SAVVY CABIN FOR SMARTER EXPERIENCES

From bluetooth audio to wireless charging, enjoy seamless connectivity in a tech-savvy cabin environment, no strings attached.



**NEW SMART SWITCH**



**UPPER TECH PANEL**



**BLUETOOTH AUDIO\***

**WIRELESS CHARGING\***



**ENJOY A VIEW OF THE SKY VIA 3 EXTERNAL CAMERAS\***



# COMMAND YOUR ENVIRONMENT

Enjoy intuitive control of your comfort with a next-generation Cabin Management System (CMS).



It's easier than ever to customize your comfort down to the individual seat.

## VOICE COMMAND INTEGRATION\*

Speak your preferences—your jet listens.

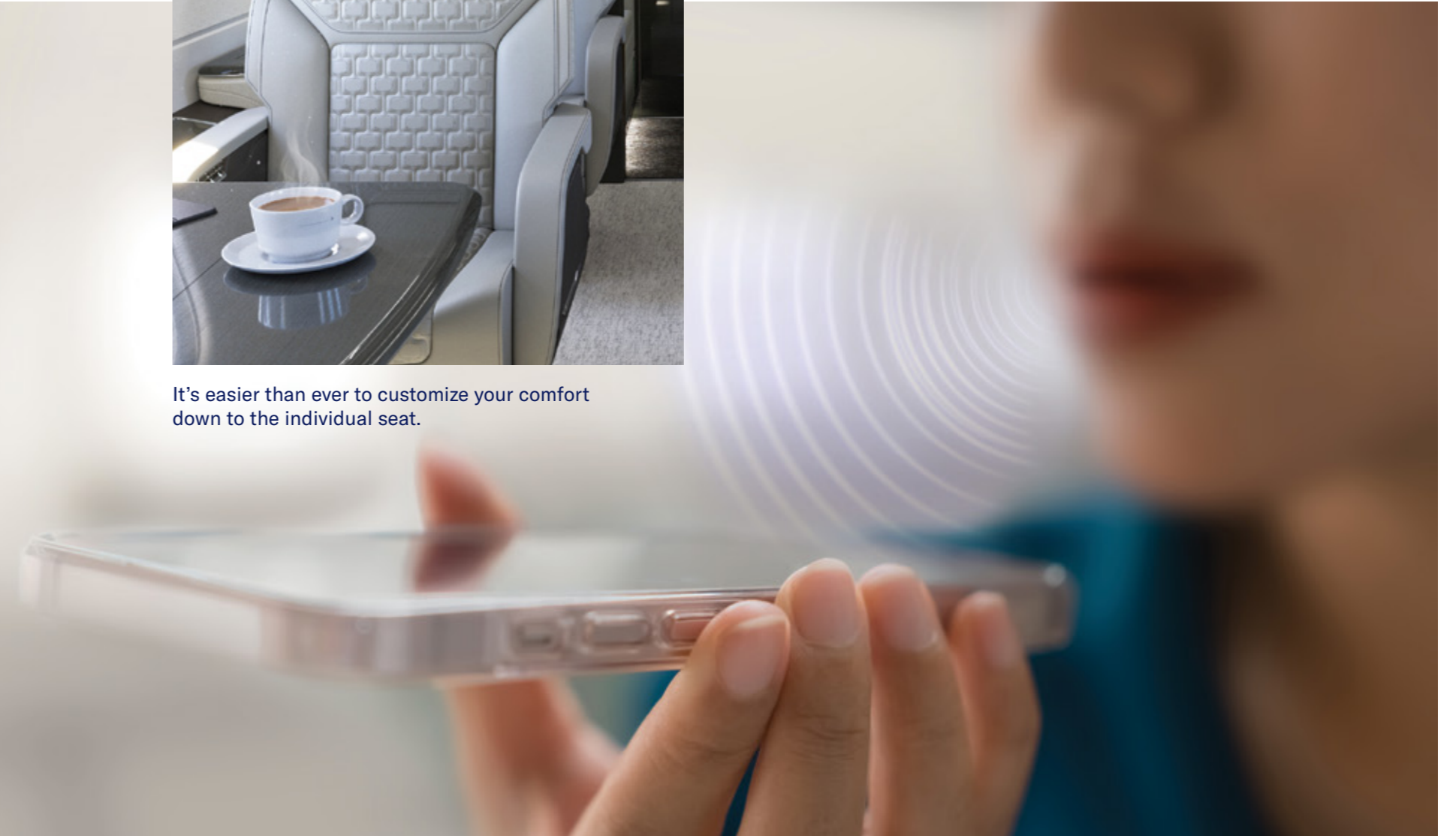

# EXPECT ONLY THE BEST

In the aircraft that means “to lead the way”, the Praetor 500E delivers industry-best cabin technology, fit for today’s innovators.

22” MONITOR



Located in the front of the cabin

OMNI-FI SOUND SYSTEM



Rich audio experience from the Red Dot awarded system

CABIN MOOD LIGHTING\*



Offers full RGB spectrum lighting

WI-FI CONNECTIVITY\*

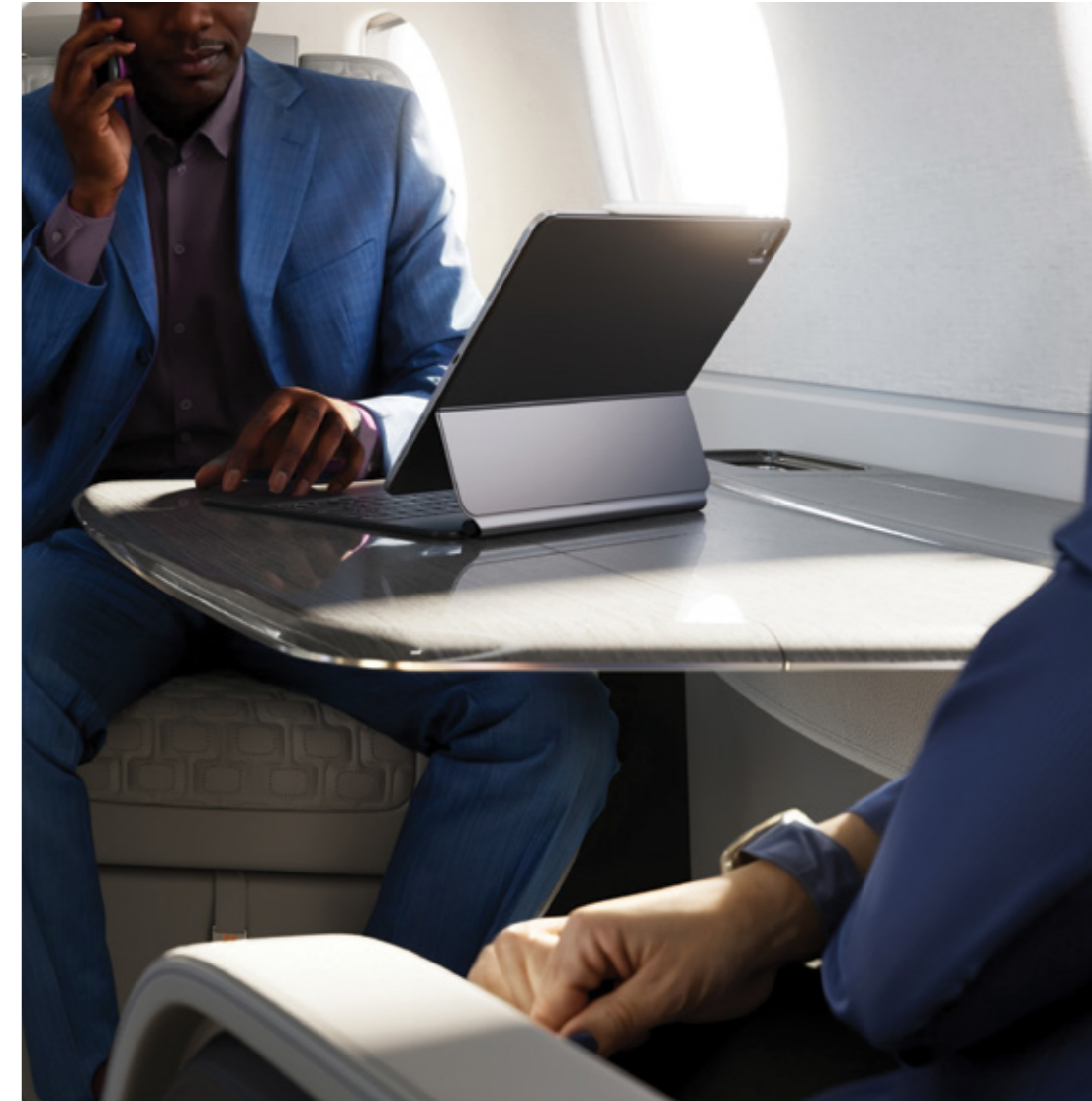

Home-like experience

**PRAETOR**<sup>®</sup> 500E  
BY EMBRAER

UNRIVALED COMFORT





## DESIGN THAT BREATHES

New cross-section: optimized to provide more headspace, opening up at eye level and adding to the spaciousness of the cabin.

6 ft 10 in  
(2.08 m)



6 ft  
(1.83 m)

Flat-floor cabin provides easier accessibility for luggage, wheelchairs, and more.

# ENGINEERED TO GO THE DISTANCE



**ELECTRIC-ASSISTED SEAT RELEASE  
& FORWARD TRACKING HEADREST:**  
Effortless adjustments, neck support  
for all positions, maximum comfort.



**NEW LOUNGE POSITION\*:**  
It's never been easier to lock  
into relaxation.

**CONFIGURABLE CUSHION FIRMNESS & DUAL LUMBAR SUPPORT\*:**  
Tailored comfort at 45,000 feet, built for extended use.

**INCREASED LEGROOM:**  
Stretch out. Stay refreshed.

# ENHANCED BERTHING

Faster, easier & more room for rest, including new incline capabilities and up to two in-flight beds.



## WORK TO REST IN SECONDS

Transform your cabin from workspace to reprieve with our simplified seat berthing process—for swift, seamless adjustments. With cabin presets, quickly curate lighting, temperature, and ambiance to match.



# TAILOR TO YOUR LIFESTYLE

Designed to maximize the utility of the cabin, whether for work, rest or recreation.

## GALLEY LAYOUT



## DIVAN LAYOUT



## 7<sup>TH</sup> SEAT LAYOUT

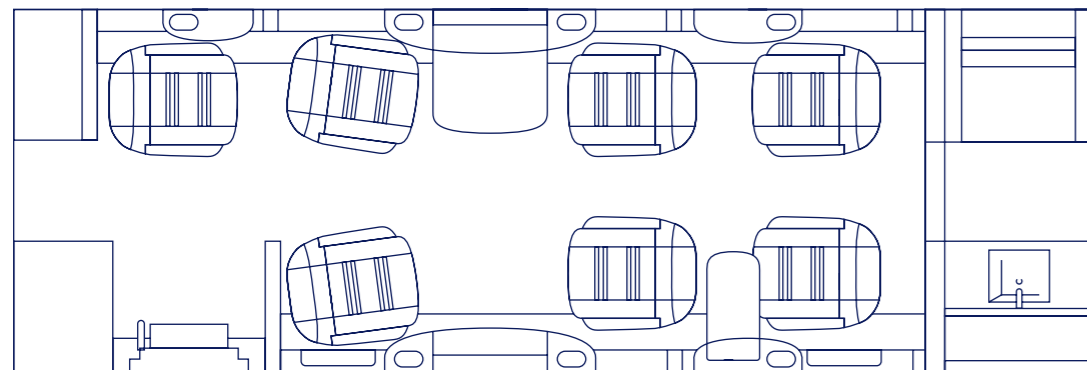

# INTERIOR COLLECTIONS

The Praetor 500E reflects your aesthetic, with three themed collections created to springboard the selection of your ultimate interior experience.

## 1. EXECUTIVE

Get the C-suite treatment for maximum maintainability, utilizing durable materials such as ultraleather, stone flooring, and quilt stitch seat inserts.

## 2. ARTISTRY

For an individualized touch, explore enhanced material selections, upgraded finishes, additional seat insert quilting styles, and optional fabric for sidewalls and bulkheads.

## 3. SIGNATURE

For ultimate style, this collection delivers the latest innovations in cabin design: more quilting styles, upgraded finishes, and exclusive materials. As an extra touch, Signature is the only collection to bring carbon fiber accents throughout the cabin.



**EXECUTIVE COLLECTION**  
**GOODWYNN**

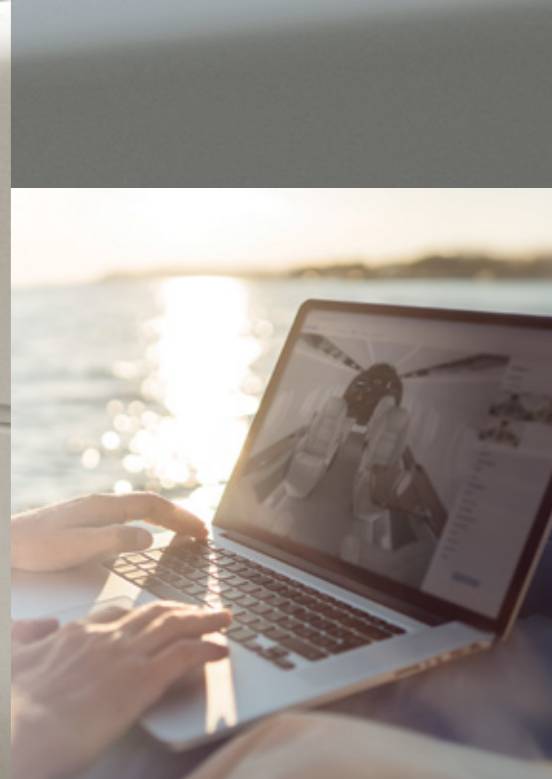

**ENJOY IT  
YOUR WAY**

Ready to visualize your jet?

Scan the QR code to access  
our full online configurator  
from your phone, tablet  
or computer.



**ARTISTRY COLLECTION**  
**SOLARA**



**SIGNATURE COLLECTION**  
**TIDAL**



# CONSIDERATE UTILITY

\*Some items are optional.

## SIDE LEDGE DESIGN



Refined to bring more capabilities close-at-hand with new Smart Switch, wireless charging\* and cupholders.

## CREW LAVATORY\*



Comfort for all, even behind the scenes. Available in place of wardrobe, in addition to side-facing seat.

## AMBIENT AIR SYSTEM



Elegant, gasper-less, and whisper-silent delivery create a considerate microclimate.

# INDULGE AT 45,000 FEET

\*Some items are optional.

Dining onboard the Praetor 500E has been re-engineered to offer more space, customization and power for continental use.

**HOME-STYLE MICROWAVE FUNCTIONALITY WITH OPTIMIZED SPACE UTILIZATION IN A COMPACT DESIGN.**

**HOME-LIKE FULL GALLEY FOR OVER 7 HOURS OF COMFORT**



REFRESHMENT CENTER



FULL GALLEY

Delivering a gourmet dining experience that ensures comfort and convenience throughout your journey

**PRAETOR**<sup>®</sup> 500E  
BY EMBRAER

BEST-IN-CLASS  
PERFORMANCE





## TAKE IT TO THE MAX

The fastest. The furthest-flying. Superior short runway performance. Unlock your access to some of the world's most challenging airports with the utmost efficiency in the maximized midsize jet. So you can focus on the next destination, not how to get there.

### PERFORMANCE CAPABILITIES

Range  
(4 passengers at 200 lb (91 kg) each, baseline aircraft, ISA temperature en route, LRC, NBAA IFR reserves with 200 nm alternate.) 3,340 nm / 6,186 km

High Speed Cruise 466 kt / 863 km/h

M<sub>MO</sub> M 0.83

Takeoff Distance (MTOW, SL, ISA) 4,222 ft / 1287 m

Landing Distance  
(Unfactored, 4 passengers, SL, ISA, NBAA IFR reserves with 200 nm alternate.) 2,086 ft / 636 m

Maximum Payload 3,363 lb / 1,525 kg

Maximum Operating Altitude 45,000 ft / 13,716 m

Propulsion Honeywell HTF7500E

Engine Thrust / Flat Rating 6,540 lb<sub>f</sub> / ISA + 18°C

Avionics Pro Line Fusion Collins Aerospace

Total Baggage and Stowage Volume 150 ft<sup>3</sup> / 4.24 m<sup>3</sup>

Seating Configuration  
(Crew + Standard Passengers / Max Passengers) 2 + 7 / 9

70 ft 6 in | 21.50 m

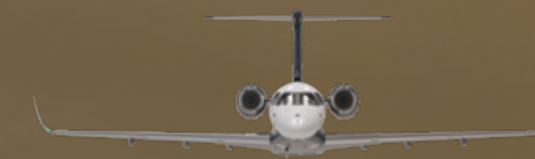

64 ft 7 in | 19.68 m



21 ft 1 in | 6.43 m  
\*Including landing gear



24 ft 1 in | 7.34 m

# CUTTING-EDGE AVIONICS

The Praetor 500E redefines technology in the super-midsize class. Its Collins Pro Line Fusion® flight deck marries advanced avionics with intuitive ergonomics for a seamless pilot-aircraft interface.



# SAFETY, REINFORCED

Complimenting full fly-by-wire, the Praetor 500E adds advanced protection with Runway Overrun Awareness and Alerting System (ROAAS), providing peace of mind during the most critical phases of flight. Additional avionics include Embraer's Enhanced Vision System with Head-Up Display, autothrottle, and Synthetic Vision Guidance System.

## Runway Overrun Awareness and Alerting System (ROAAS)



An advanced system designed to act like a virtual pilot during the most critical phase of flight, providing protection and peace of mind.

## Full fly-by-wire with active turbulence reduction



With digital, side-stick controls, full fly-by-wire reduces pilot workload, provides a smoother flying experience, and opens access to more airports.

## Autothrottle

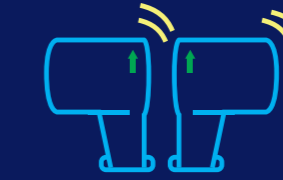

Automatically adjusts engine thrust to maintain the desired airspeed or power setting.

## Embraer Enhanced Vision System with Head-Up Display (E2VS)

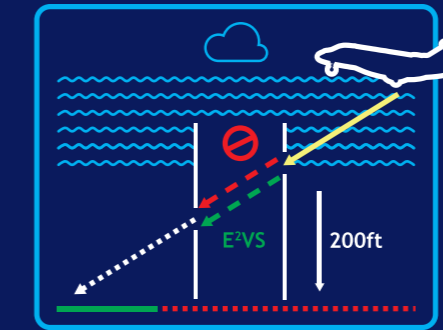

See through weather systems with advanced situational awareness.

## Synthetic Vision Guidance System (SVGS)



See what the human eyes cannot with increased situational awareness.

# COMMAND THE SKY

The Praetor 500E brings unprecedented technology to the cockpit as the first and only jet in its class to feature full fly-by-wire digital controls with active turbulence reduction, for utmost safety and unmatched comfort. Full fly-by-wire with side-stick controls unlocks a cascade of benefits for pilots and passengers alike—reduced workload, a smoother flight experience, greater access to more airports through its enviable short runway performance, and lower downtime for maintenance that translates to more time in flight.



## BEST-IN-CLASS RANGE

When put to the test, the Praetor 500E defies all expectations of what a midsize jet can do with a nonstop long-range cruise of 3,340, nm—the best in its class.

In this jet, the world is your oyster.



# THE WORLD IS YOURS

Traverse continents with ease onboard the furthest-flying midsize jet. Fly from Miami to Seattle, Dubai to Monaco, or São Paulo to San Juan. And it's the only of its class able to consistently fly from New York to London nonstop.



**NEW YORK TO LONDON**



**MIAMI TO SEATTLE**



**DUBAI TO MONACO**



**SÃO PAULO TO SAN JUAN**



## WORLDWIDE SUPPORT

The ultimate experience isn't complete without around-the-world support, 24 hours a day, 365 days a year. With an ever-expanding network of owned and authorized service centers, comprehensive service portfolio, customizable solutions, and pilot training facilities, Embraer is consistently top-ranked as a world leader in customer support.



Scan QR code to learn more about Services & Support

# THE ULTIMATE EXPERIENCE IN BUSINESS AVIATION

Embraer delivers the ultimate experience in business aviation through aircraft that feature disruptive performance, technology and comfort. Its portfolio consists of the Phenom 100EX, which offers unmatched cabin comfort, the highest levels of operational versatility and enhanced pilot-centric avionics; the Phenom 300E, which has been the best-selling light jet for over a decade; the Praetor 500E, the midsize jet maximized to fly furthest, fastest, in unrivaled cabin comfort; and the Praetor 600E, the world's furthest-flying super-midsize jet, reimagined for a next-gen cabin experience.



## PRAETOR 500E

Category: Midsize	Crew + Max. passengers: 2 + 9	Speed: M 0.83
Range: 3,340 nautical miles (4 pax, NBAA reserves)		

Experience a jet like none other in the midsize that flies furthest, fastest and in unrivaled cabin comfort. Equipped with category-exclusive full fly-by-wire with active turbulence reduction, the Praetor 500E is maximized to go the distance.

## PHENOM 100EX

Category: Entry-level	Max. occupants: 8	Speed: M 0.70
Range: 1,178 nautical miles (4 occupants, NBAA reserves)		

Experience excellence through unmatched cabin comfort, the highest levels of operational versatility and enhanced pilot-centric avionics including Runway Overrun Awareness and Alerting System (ROAAS).

## PHENOM 300E

Category: Light	Max. occupants: 11	Speed: M 0.80
Range: 2,010 nautical miles (5 occupants, NBAA reserves)		

An aircraft of legendary reputation as the fastest and furthest-flying in its category, the Phenom 300E is the best-selling light jet for over a decade, featuring advanced technology such as ROAAS (Runway Overrun Awareness & Alerting System) and autothrottle.

## PRAETOR 600E

Category: Super-midsize	Crew + Max. Passengers: 2 + 12	Speed: M 0.83
Range: 4,018 nautical miles (4 pax, NBAA reserves)		

Different by design and disruptive by choice, the Praetor 600E delivers a next-gen cabin experience, best-in-class range, and category-exclusive full fly-by-wire with active turbulence reduction.





Contact us

